

maskin mekano

ECO6
MOBILE SCREENING PLANT



Speedy screening with ECO6

Between workplaces at 80 km/h! ECO6 is registered and approved to drive as a trailer in the EU, which means you can drive everywhere, even on highways, with no need of special permits. Smooth, fast and easy to transport in other words.

Maskin Mekano's screens are developed for tough conditions. With a strong stroke (12 mm) and relatively flat angle (11°), you get an unmatched combination of capacity and screening accuracy even when the conditions and weather are not optimal. Fine fractions are sorted with remarkable precision, but few materials are any challenge for the Maskin Mekano STE screen. Thanks to the Vibrobloc technology, no vibrations transfer into the machine, but stay in screen box where they belong. The belt feeder is well proven, as are all the solutions in this screening plant, which is based on Maskin Mekano's long experience and knowledge in the crushing and screening industry.

The ECO6 is robust and well-built with the operator's safety in focus, fixed sturdy walkways and railings are examples of this, as are the unique intervention protections. The screening plant is electrically powered and can be run on mains power if available.

Full speed without problems both in production and on the road!

DECKS



2

SCREEN AREA

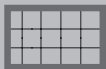

1.4 X 4.8

WEIGHT



24.000

TRANSPORT



Towing

CONSUMPTION



22 kWh

4.5 l/h

SET UP TIME



10 minutes







Screen STE 2-67

The ECO6 is equipped with the proven STE 2-67 screen. It measures 1.4 x 4.8 metres on two decks. The aggressive stroke (12 mm) cascades the material. It is almost horizontal (11°) for precise division of fine material. The capacity per square meter screening area is unequalled in the market.

The upper deck is side tensioned in order to endure the heavy load of coarser fractions and the lower deck is end tensioned to maximise the capacity for screening fines and it can be fitted with a ball-deck to increase capacity when screening challenging materials. Changing meshes is cheap, easy and quickly done. The open construction gives full accessibility to the screen box for ease of maintenance and inspection. The lower deck can be reached from the catwalk behind the screen box, but is also accessible in the front through the hydraulically sliding chutes.

STEscreens 

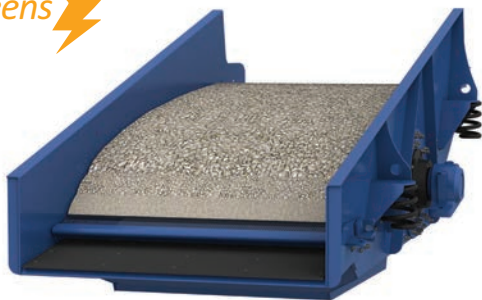

FEATURE	EFFECT	RESULT
Powerful stroke	Effective stratification	High capacity
Almost horizontal	Effective separation	High quality

The STE-screen is really versatile. Crushed material can be separated down to 2 mm, but feeding a 0-250 mm is no problem either. Because of the powerful stroke all kinds of difficult materials are able to be processed as well.

The Vibroblock concept

The Maskin Mekano Vibroblock concept means the screen box is mounted on a vibration damped frame which prevents the vibrations from the screen from transmitting to the chassis. This saves the entire plant from damages caused by vibration, whilst the screening motion remains efficient. The Vibroblock design allows the STE screen to operate with the capacity of a four bearing screen as smooth as a two bearing screen, and keeps the power in the screen-box where it belongs.

VibroBLOCK 





Feeding

The feeding unit consists of a 7 m³ heavy-duty hopper with a reject grid and a powerful belt feeder. Tipping of the reject grid is performed hydraulically via remote control, and the distance between the bars is 150 mm. The reject grid tips a full 90° and is self-cleansing. The feeding speed is also controlled via remote control as is the opening of the feeding chute. The belt feeder is driven by a powerful rubber fitted drum motor.

Stockpiling

The ECO6 is fitted with three conveyors which are totally integrated and hydraulically folded, set-up time is less than 10 minutes. The folding is performed without any twisting of the belts. The motorized pulleys are gummed for operating security even in bad weather.

Construction

The ECO6 is built as a heavy duty road trailer with twin suspended and ABS-braking axles. The strong but low weight construction is designed to minimize vibrations during operation as well as for

high towing stability. The machine is raised and lowered by means of a hydraulic lifting leg and two separate jacking legs. King-pin 2'' for towing. For maximum operator security there are sturdy on-board wrap around catwalks and hydraulically foldable ladders.

Electric drive

The ECO6 is fully electric, reducing the environmental impact to a minimum. Noise impact is also significantly reduced.

If a diesel generator 65 kVA (optional) is needed it is mounted on a separate frame that can be lifted down with the scoop. Moving the generator several meters away from the worst dust means that the strain on the filter and other vital components is significantly reduced. The fuel consumption is 4-5 litres per hour.

Profitable investment

Because of the rugged construction a Maskin Mekano plant keeps the value like no other plant. The outstanding capacity and low operating costs make the investment profitable. The high second-hand value makes it safe. All wear and spare parts are stored in Jönköping and all customers are given professional advice and support from our service engineers.

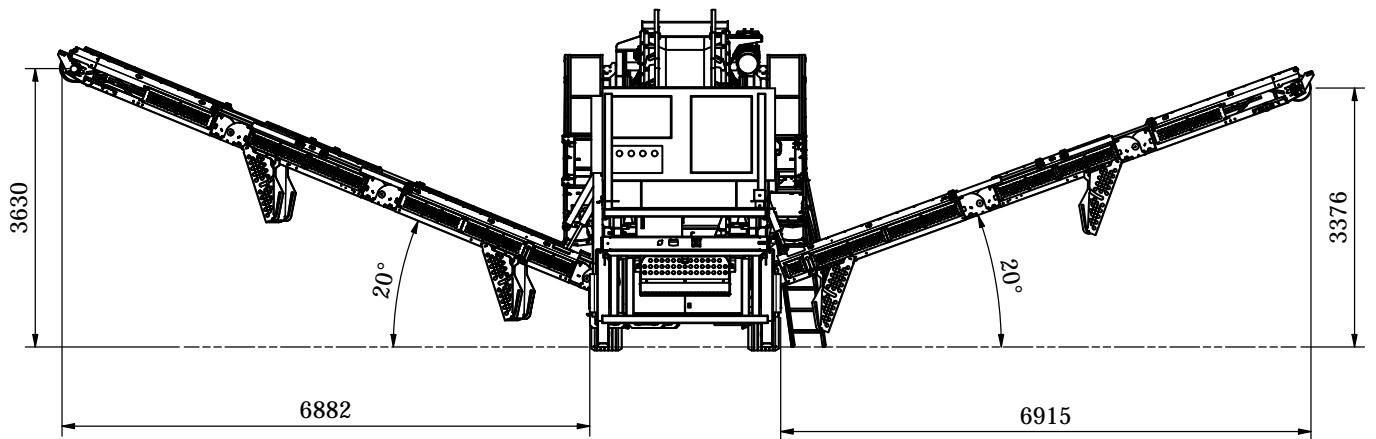
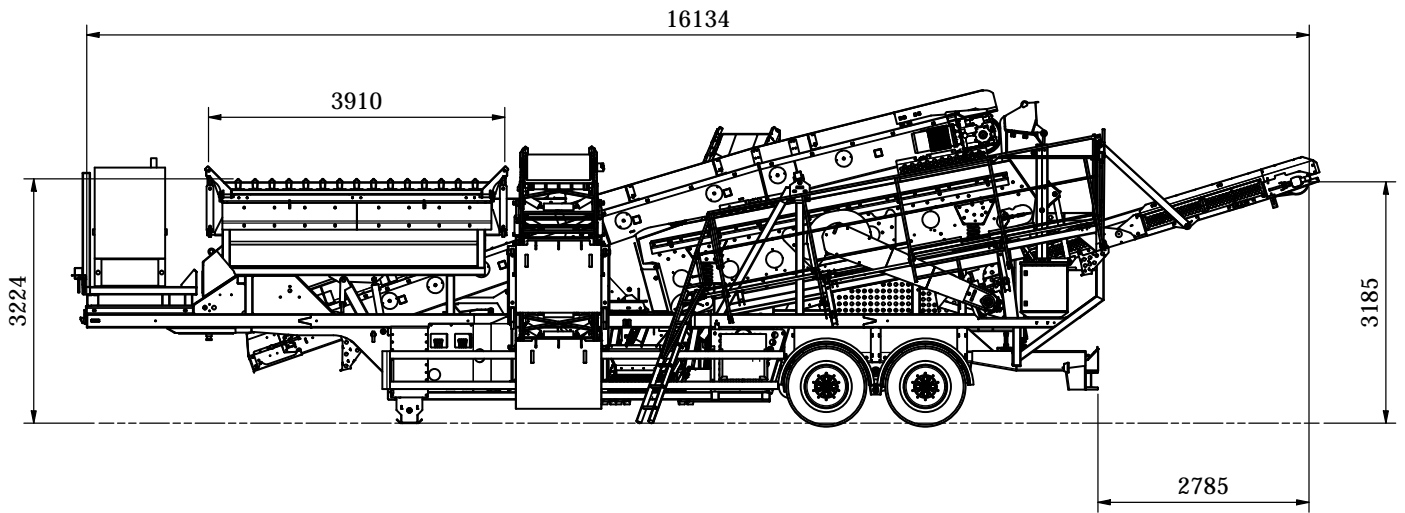
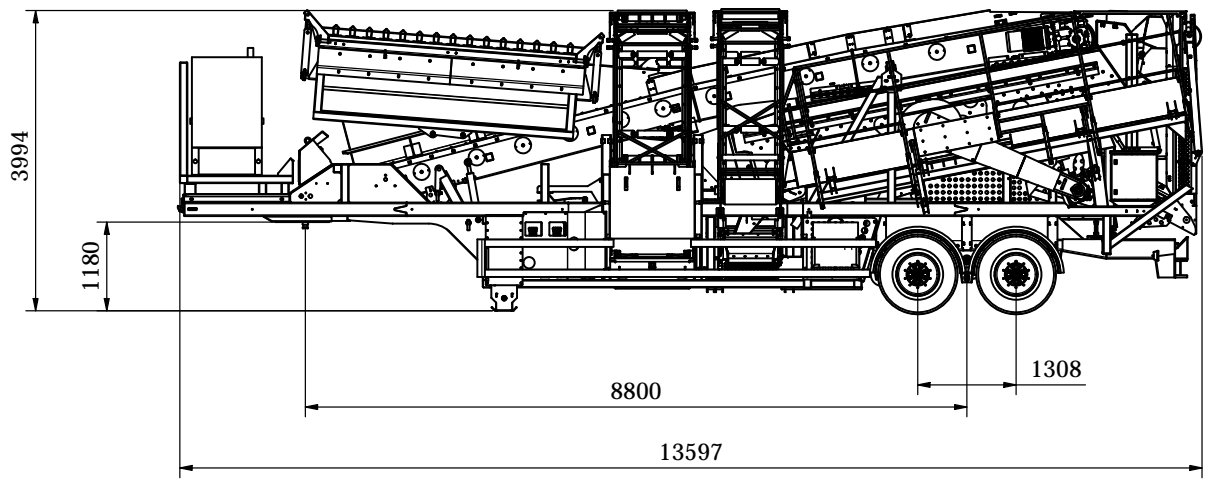

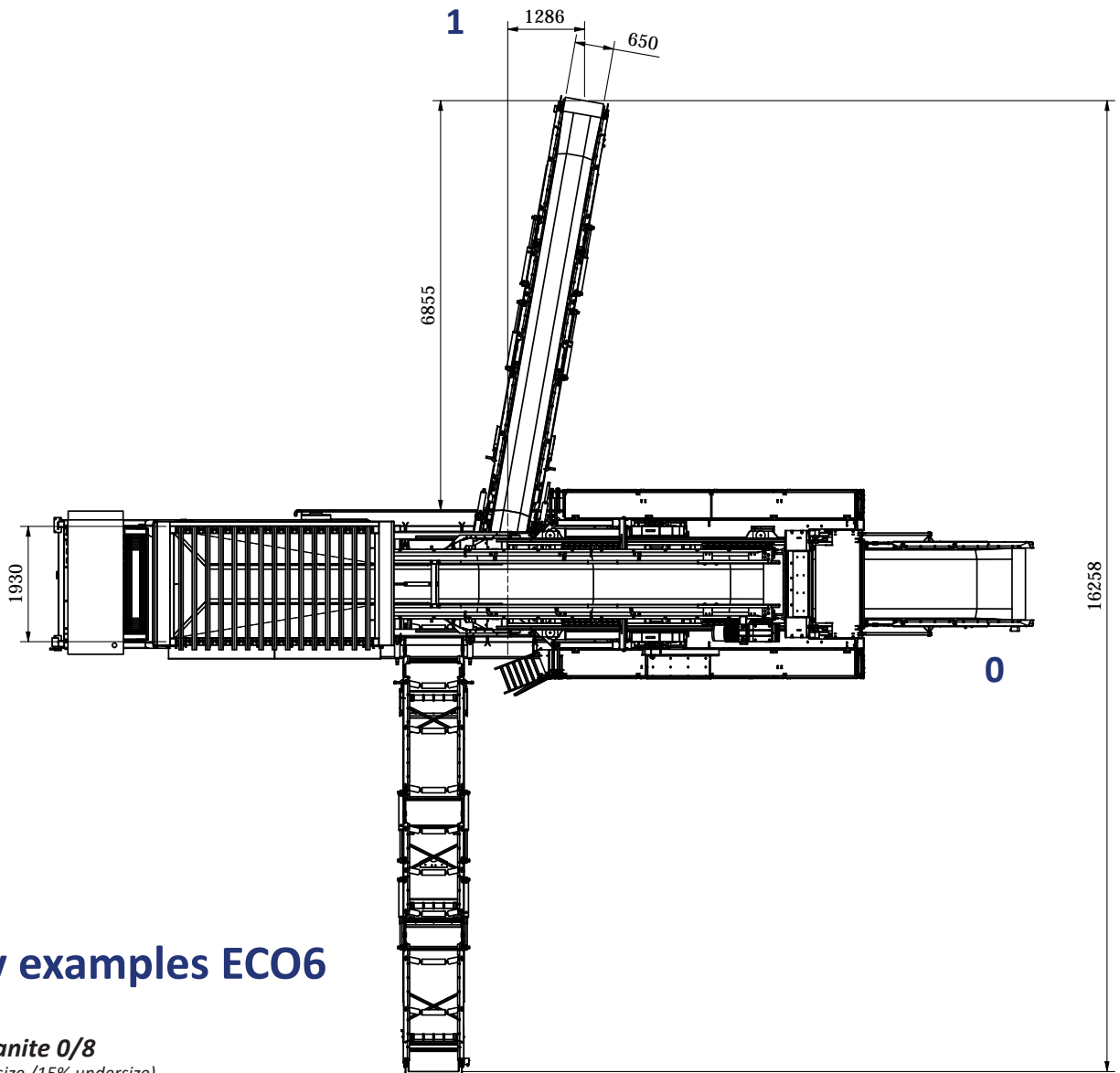

Capacity examples ECO6

Crushed granite 0/8

(max. 10% oversize /15% undersize)

	Size	Share	tonnes/h
0	0/2	51%	59
1	2/4	19%	22
2	4/8	29%	34
			115

Crushed granite 0/11

(max. 10% oversize /15% undersize)

	Size	Share	tonnes/h
0	0/4	59%	82
1	4/8	24%	34
2	8/11	16%	22
			138

Crushed granite 0/16

(max. 10% oversize /15% undersize)

	Size	Share	tonnes/h
0	0/4	51%	82
1	4/8	21%	34
2	8/16	28%	45
			160

Technical Specification Maskin Mekano ECO6

<i>Transport Length</i>	13.6 m
<i>Transport Width</i>	2.55 m
<i>Transport Height</i>	4.0 m
<i>Machine Weight</i>	approx. 24 tonnes (not including Dieselgenerator set)
<i>Bogie pressure</i>	approx. 16 tonnes
<i>Screenbox</i>	STE 2-67 Screening surface 1.4 x 4.8 m on two decks Single axle mechanically controlled with 12 mm stroke 11° incline Electric motor 11.0 kW, 400 V
<i>Beltfeeder</i>	Width 1000 mm Length 10.4 m Electric motor 7,5 kW
<i>Hopper & Reject grid</i>	Volume 7 m ³ Standard distance between bars 150 mm, adjustable Hydraulic tipping, self cleaning
<i>Conveyor plusize</i>	Belt width 800 mm Length 9.9 m Electric drum motor 4.0 kW Height under the drum drive 3.5 m
<i>Conveyor midsize</i>	Belt width 650 mm Length 9.9 m Electric drum motor 4.0 kW Height under the drum drive 3.8 m
<i>Conveyor fines</i>	Belt width 1200 mm Length 7.9 m Electric drum motor 5.5 kW Height under the drum drive 3.1 m
<i>Electric equipment</i>	Electrical distribution box with integrated touchscreen mounted on the machine including safety breaker, safety disconnection breaker, emergency stop, preregulator as well as extra motor socket. Power inlet with 125 A CEE-device
<i>Hydraulic equipment</i>	Hydraulic aggregate for setting up, folding of the conveyors and grid lift. Motor 4.0 kW
<i>Wheel- and towing device</i>	Bogie with brakes, ABS-system and plate springs. Wheel dimension 22.5/65/385, 10 bolt. Towing device, 2" kingpin as standard

Our policy is one of continuous improvement and we reserve the right to change the detailed specification of our products at any time without prior notice.

ADVANTAGES OF ALL OUR PLANTS:

CARBON FOOTPRINT



Electric drive
OR low emissions

VIBRATIONFREE



The Vibroblock
concept

SCREEN CAPACITY



Aggressive stroke

NOISE IMPACT



Very low

OPERATOR SAFETY



Protection according
to regulations

OVERVIEW



Touchscreen in
electrical cabinet

MADE IN SWEDEN



maskin mekano

Address: Maskin Mekano AB, Box 9083, 550 09 Jönköping, SWEDEN,

Phone: + 46 36 31 74 00

E-mail: info@maskinmekano.se

www.en.maskinmekano.se