

maskin mekano

**Ls 1202**

MOBILE SCREENING PLANT



# Adaptable screening

The Ls 1202 is the best traditional screening plant for screening sand, gravel, top-soil and so on.

The 1200-range comes in various editions; with or without feeder, belt feeder or vibrating feeder, the optional diesel generator, featuring a screen with two or three decks. Fitted with a roter (PD-edition) it becomes a giant top soil screener, it also comes as the recycling (R) edition. The electrical drive, the screening ability and the sturdy design are however common.

The Maskin Mekano screens are designed for Scandinavian conditions. The combination of an aggressive stroke and low inclination provides an unequalled screening capacity and screening accuracy when the weather is challenging.

DECKS



2

SCREEN AREA



1.4 X 4.8

WEIGHT



24.000

TRANSPORT



Towing

CONSUMPTION



22 kWh

4.5 l/h

SET UP TIME



10 minutes





maskin mekano

Ls 1202

KING

11B



## Screen STE 2-67

The Ls 1202 is equipped with the proven STE 2-67 double-deck screen. The aggressive stroke (12 mm) cascades the material. It is almost horizontal for precise division of fine material. The capacity per square meter screening area is unequalled in the market.

The upper deck is side tensioned and the lower deck is end tensioned, it can be fitted with a ball-deck to increase capacity when screening challenging materials. Changing meshes is cheap, easy and quickly done. The open construction gives full accessibility to the screen box for ease of maintenance and inspection. The feeding conveyor can be raised for total access to the upper deck, and the chutes are foldable so that the lower deck is easier to reach.

The STE-screen is really versatile. Crushed material can be separated down to 8 mm, but feeding a 0-250 mm is no problem either. Because of the powerful stroke all kinds of difficult materials are able to be processed as well.

## The Vibroblock concept

The Maskin Mekano Vibro Block concept means the screen box is mounted on a vibration damped frame which prevents the vibrations from the screen from transmitting to the chassis. This saves the entire plant from damages caused by vibration, whilst the screening motion remains efficient. The Vibro Block design allows the STE screen to operate with the capacity of a four bearing screen as smooth as a two bearing screen, and keeps the power in the screen-box where it belongs.

## Feeding

The feeding unit consists of a heavy-duty hopper and a powerful vibrating feeder or if you prefer, a beltfeeder. The hopper holds 8 m<sup>3</sup>, the feeder is clad with Hardox, and the speed is controlled via radio transmitter. Tipping of the reject grid is performed hydraulically via remote control, and the distance between the bars is adjustable. The reject grid tips a full 90° and is self-cleansing. The hopper can be fitted with heating and/or be clad in Hardox.





## Stockpiling

The Ls 1202 is fitted with a rear conveyor of 8.3 m for great stockpiling capability. The front and side conveyors are totally integrated and hydraulically folded, set-up time is less than 10 minutes. The folding is performed without any twisting of the belts. The motorized pulleys are gummed for operating security even in bad weather.

## Construction

The Ls 1202 is mounted on a heavy duty road trailer with twin suspended and braking axles. The strong construction is designed to minimize vibrations during operation as well as for high towing stability. The machine is raised and lowered by means of a hydraulic lifting legs and two separate jacking legs. King-pin 2" for towing. For maximum operator security there are sturdy onboard wrap around catwalks and hydraulically foldable ladders.

## Low fuel consumption

All Maskin Mekano plants are electrically driven which means their diesel consumption is up to 60% lower than hydraulically driven plants. The Ls 1202 consumes 4-5 litres of diesel per hour. Noise impact is reduced to a minimum.

## Diesel Generator

The diesel generator (optional) is mounted on a separate frame that can be lifted down with the scoop. Moving the generator several meters away from the worst dust means that the strain on the filter and other vital components is significantly reduced.

## Profitable investment

Because of the rugged construction a Maskin Mekano plant keeps the value like no other plant. The outstanding capacity and low operating costs make the investment profitable. The high second-hand value makes it safe. All wear and spare parts are stored in Jönköping and all customers are given professional advise and support from our service engineers.



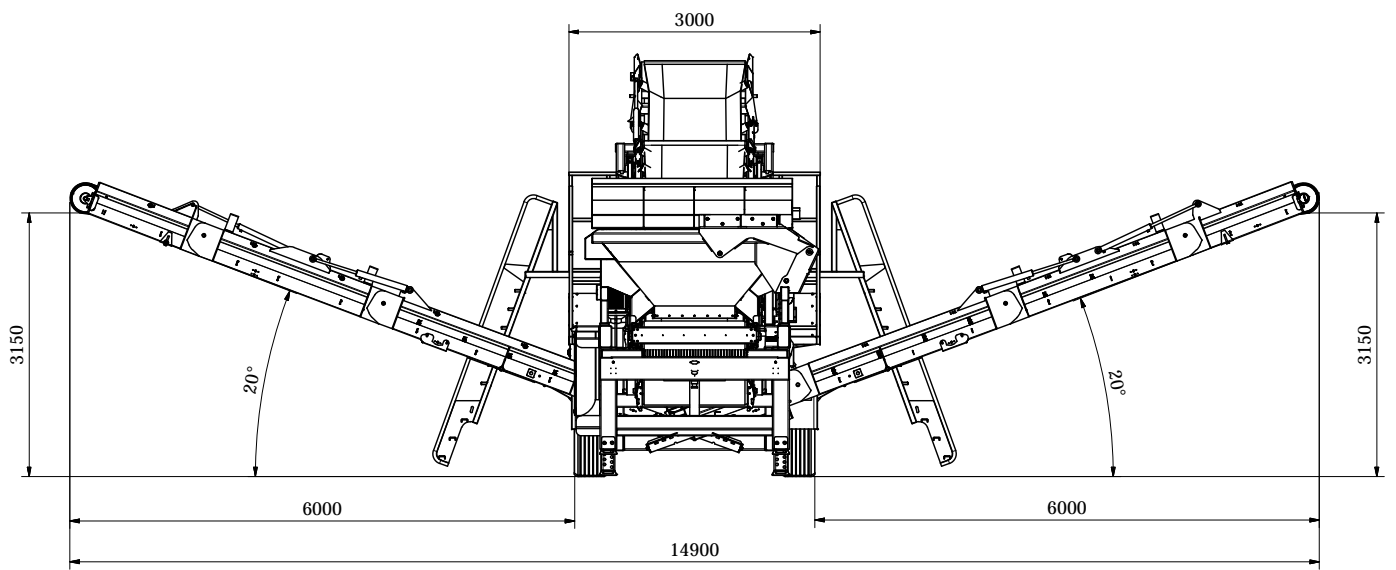
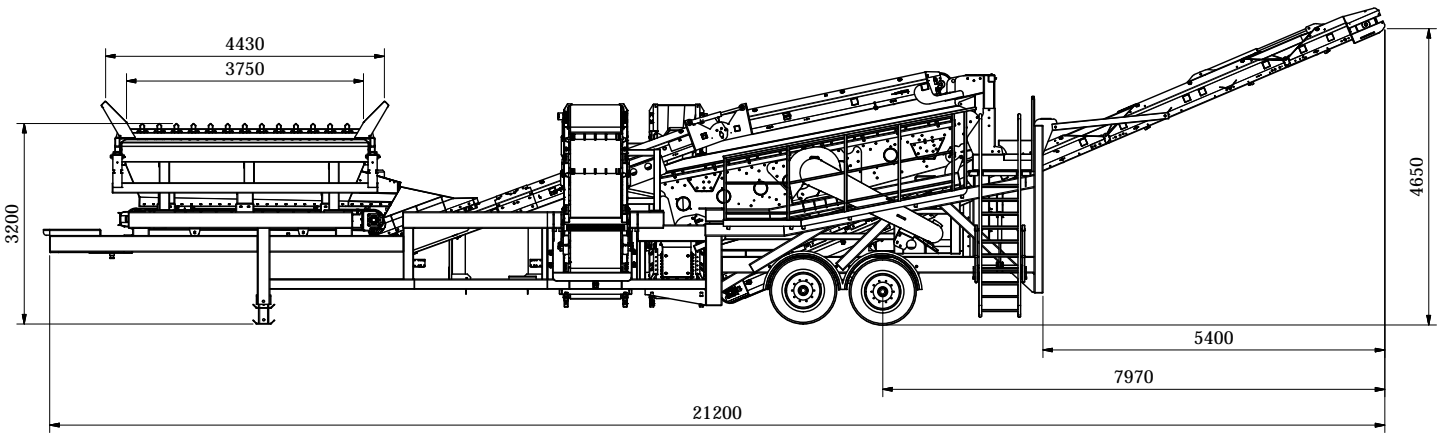
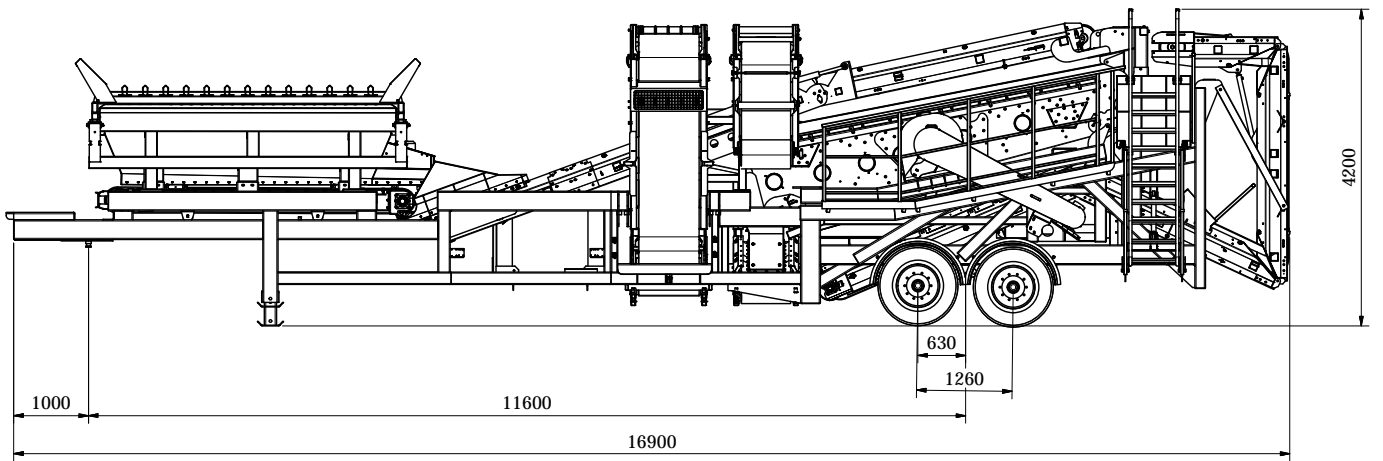

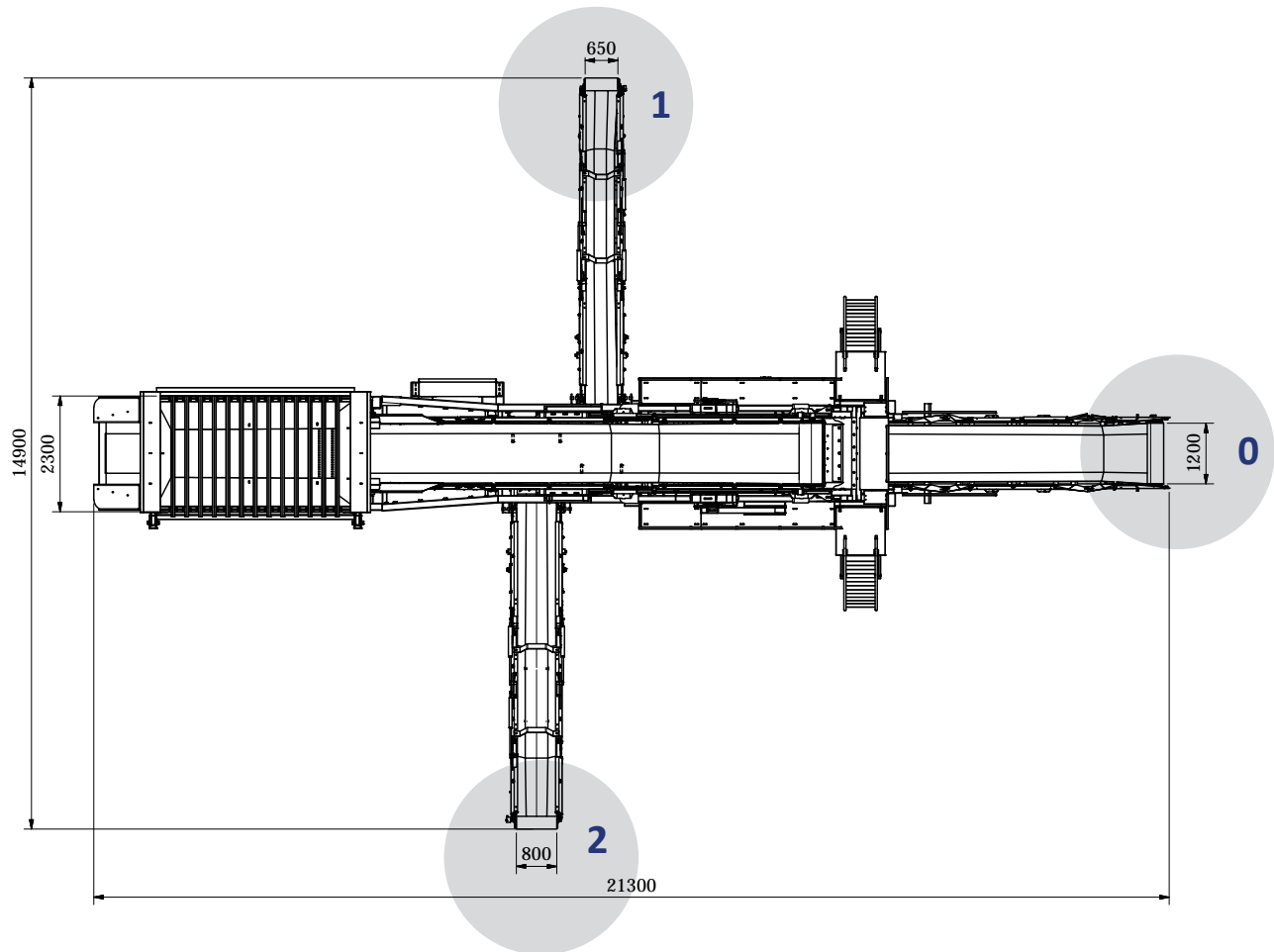

## Capacity examples two-deck screens

Sorting of 0/8 with approved curves (max. 10% oversize /15% undersize)

			1200-range	1500-range
	Size	Share	tonnes/h	tonnes/h
0	0/2	51%	59	83
1	2/4	19%	22	32
2	4/8	29%	34	47
			115	162

Sorting of 0/11 with approved curves (max. 10% oversize /15% undersize)

			1200-range	1500-range
	Size	Share	tonnes/h	tonnes/h
0	0/4	59%	82	115
1	4/8	24%	34	47
2	8/11	16%	22	32
			138	194

Sorting of 0/16 with approved curves (max. 10% oversize /15% undersize)

			1200-range	1500-range
	Size	Share	tonnes/h	tonnes/h
0	0/4	51%	82	115
1	4/8	21%	34	47
2	8/16	28%	45	63
			160	225

## Technical Specification Maskin Mekano Ls 1202

<i>Transport Length</i>	16.9 m
<i>Transport Width</i>	3.0 m
<i>Transport Height</i>	4.2 m
<i>Machine Weight</i>	approx. 24 tonnes (not including Dieselgenerator set)
<i>Boggie pressure</i>	approx. 14 tonnes
<i>Screenbox</i>	STE 2-67 Screening surface 1.4 x 4.8 m on two decks Single axle mechanically controlled with 12 mm stroke 11° incline Electric motor 11.0 kW, 400 V
<i>Vibrating/Belt feeder</i>	Width 1100/1200 mm Length 4000 mm Electric motor 2 x 3.2 kW/ 7,5 kW
<i>Hopper &amp; Reject grid</i>	Volume 8 m <sup>3</sup> Standard distance between bars 190 mm, adjustable Hydraulic tipping, self cleaning
<i>Main conveyor</i>	Width 1200 mm Length 10.5 m Electric drum motor 5.5 kW
<i>Side conveyors</i>	Belt width 650/800 mm Length 8.5 m Electric drum motor 4.0 kW
<i>Rear conveyor</i>	Belt width 1200 mm Length 11.5 m Electric drum motor 5.5 kW
<i>Electric equipment</i>	Electrical distribution box with integrated touchscreen mounted on the machine including safety breaker, safety disconnection breaker, emergency stop, preregulator as well as extra motor socket. Power inlet with 125 A CEE-device
<i>Hydraulic equipment</i>	Hydraulic aggregate for setting up, folding of the conveyors and grid lift Motor 4.0 kW
<i>Wheel- and towing device</i>	Bogie with brakes and plate spring. Wheel dimension 22.5/65/385, 10 bolt. Towing device, 2" kingpin as standard

*Our policy is one of continuous improvement and we reserve the right to change the detailed specification of our products at any time without prior notice.*

### ADVANTAGES OF ALL OUR PLANTS:

#### CARBON FOOTPRINT



Electric drive  
OR low emissions

#### VIBRATIONFREE



The Vibroblock  
concept

#### SCREEN CAPACITY



Aggressive stroke

#### NOISE IMPACT



Very low

#### OPERATOR SAFETY



Protection according  
to regulations

#### OVERVIEW



Touchscreen in  
electrical cabinet

#### MADE IN SWEDEN



# maskin mekano

Address: Maskin Mekano AB, Box 9083, 550 09 Jönköping, SWEDEN,

Phone: + 46 36 31 74 00

E-mail: [info@maskinmekano.se](mailto:info@maskinmekano.se)

[www.en.maskinmekano.se](http://www.en.maskinmekano.se)